

FEATURES

- CE ROHS certificate approval.
- Output voltage from 12 to 120 VDC, output current auto adjustable.
- Used with 3.7V 2000MAH lithium Ion battery pack. The battery is built into the box.
- Perfectly compatible with both DC LED loads and AC LED external driver.
- Emergency operation of LED light source and luminaries in extreme temperature from -0°C to 50°C(0°F to 122°F).
- 2 years Warranty.
- Accessory: test switch and charge indicator.



CHARACTERISTICS

Item	Data
Model name	DF268C
Input voltage	AC90-280V/50-60HZ
Charging current	200 mA Max
Rated power	50W Max
Emergency output power	2W (5W Max)
Output voltage	12-120VDC
Output current	800 mA Max
Power factor	≥0.9
Battery	Li-ion 3.7V 2000MAH
Charging time	24 hours
Duration time	120 minutes
Efficiency	≥0.7
Design life time	5 years
Warranty	2 years
Charging cycles	500-2000
Abnormal protection	Over load ,no-load ,open circuit , Short-circuit ,overcharge , Over-discharge protection
Model size	L150 x W40 x H30 [mm] L5.91 x W1.57 x H1.18 [inch]
Operation temperature	0 °C to 50 °C (0°F to 122°F)

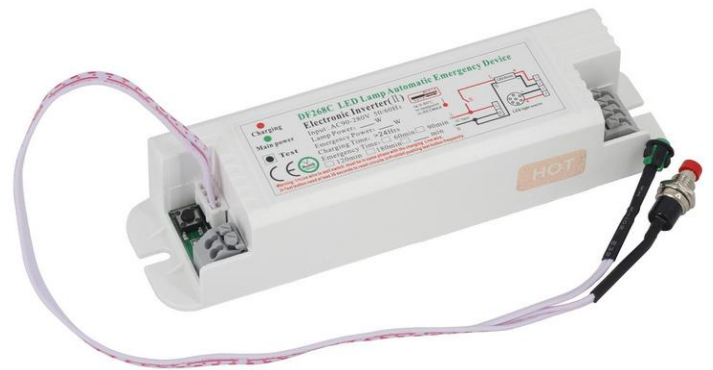

DIMENSIONS

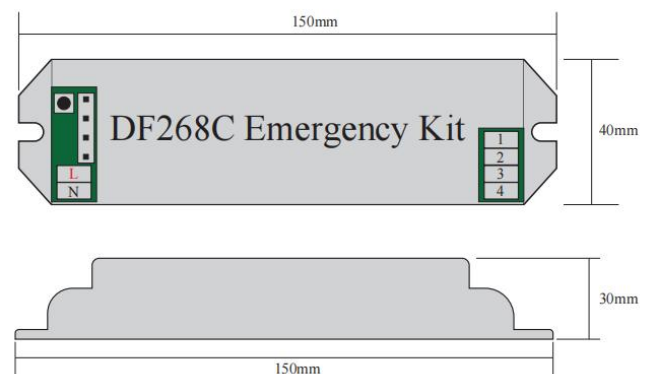

Inverter	L1	L2	W	H
	mm[inch]	mm[inch]	mm[inch]	mm[inch]
DF268C	150[5.91]	140[5.51]	40[1.57]	30[1.18]

APPLICATIONS

- 1.The product can operate with most LED lamps For normal of LED , need an extra LED driver.
- 2.The emergency power and time are customized.
- 3.Plastic housing with built-in battery.
- 4.Not intended for use in luminaries for high-risk task area lighting.
- 5.IP20 protection, relies on end-product enclosure for protection against accidental contact-live parts and achieve IP65 rating.
- 6.Suitable for indoor, dry and damp applications.

WIRING INSTRUCTIONS

- L—— Connect Live Wire TL+ LED external driver live wire input . This LED driver line can set a wall switch S.
- N—— Connect the null line N+LED external driver null line input.
- 1—— Connect LED driver's output positive.
- 2—— Connect LED driver's output negative.
- 3—— Connect LED's negative.
- 4—— Connect LED's positive.

WIRING DIAGRAMS

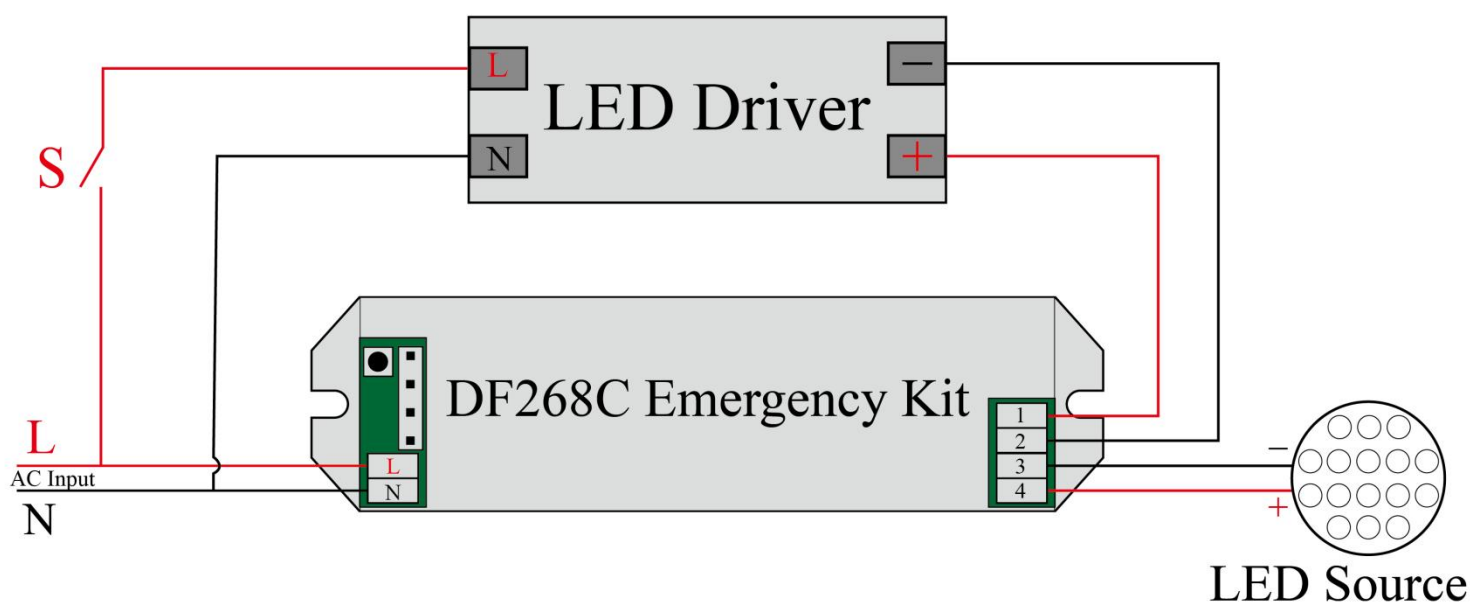

NOTICE

- (1) Wiring should be done by professional electricians or technicians. The circuit must be connected when the power is off. Live work is strictly prohibited to avoid accidents.
- (2) Main power line: Live line L and neutral line N, directly connected to the main power line, these two lines are forbidden to be connected to switches;
- (3) The wall switch only controls mains lighting, and the wall switch live wire SL and the charging live wire TL must be in the same phase;
- (4) Green Light-main power; Test Button-When there is power, press and hold the test button for 3-5 seconds to force the emergency state and test the emergency function.
- (5) In the emergency lighting state, only the light source illuminates, and all emergency power supply indicator lights are turned off.
- (6) You should connect the led lamp and charge the emergency pack before use. In order to avoid emergency lighting function failure.
- (7) The environment temperature of Emergency pack ranges from minus ten degrees centigrade to 50 degrees centigrade. High-temperature aging test is forbidden.
- (8) Do not use this product for other than intended use.
- (9) Emergency power supply testing should not be frequent, and the interval between each time should be greater than 1 minute. It is prohibited to press the test switch frequently.
- (10) As this product contains batteries, please be sure to store it in an indoor environment between 0 °C to 50°C . It must be fully charged and discharged every 6 months from the date of purchase until it is officially put into use, then recharged 30-50% and stored for another and so on. If the battery is not used for more than 6 months, it may cause excessive self-discharge of the battery , and the resulting reduction of battery capacity is irreversible. For products with separate battery and emergency module, please disconnect the connection between battery and module for storage. Due to its chemical properties, it is a normal situation for the battery capacity to decline naturally during use. Users should take this into account when choosing products.
- (11) Ensure product compatibility before final installation. Make sure the polarity is correct when connecting the batteries. Wiring should be strictly in accordance with the wiring diagram, wiring errors will damage the product. A case of safety accident or product failure caused by users' illegal operation does not belong to the scope of customer complaint acceptance, compensation or product quality assurance.
- (12) Any problem, contact the manufacturer or supplier please.